



- Monitoring relays – MMR17 series
- Monitoring of phase sequence and phase failure
- Monitoring of asymmetry
- Regulation of asymmetry and the time delay
- Connection of neutral wire optional
- Supply voltage = measuring voltage
- 1 change over contact
- Width 17.5mm
- Installation design



1

Technical data

Description

Output circuit		
Contact arrangement		1 CO
Rated voltage	V AC	250/400
Switching current range AC1	A/V AC	8/250
DC1	A/V DC	8/24
Switching load range AC1	VA	2 000
Contact resistance	mΩ	≤ 100
Max. rated current	A	8
Input circuit		
Terminals		L1, L2, L3, N, V1, V2, V3
Supply voltage U_n , AC (50-60Hz) = measured voltage	V	3x400/230
Tolerance		0,8...1,1 U_n (184...253V)
Phase power supply control system		L1
Rated consumption	VA	≤ 8
Rated frequency	Hz	47...63
Rated surge voltage	V	4 000
Insulation		
Insulation rated voltage	V AC	400
Rated surge voltage	V	4 000 1,2/50μs
Overvoltage category		III
Dielectric strength		
• Input – output	V AC	4 000
• Open contact		1 000
Measuring circuit		
Regulation range asymmetry U_{asym}	V	30...70V
Functions		MA, MS
Setting accuracy	%	≤ 5
Repeatability	%	≤ 2
Time module data		
Setting range of time off delay	s	1...6
Recovery time	s	1,2
Reset time	ms	≤ 500
The accuracy of the timing	%	20
General data		
Electrical life AC1 at 1000 VA resistive load	cycles	≥ 1,5 x 10 ⁵
Mechanical life	cycles	≥ 1 x 10 ⁷
Dimensions (L x W x H) / Weight	mm / g	90 x 17,5 x 66 / 50g
Ambient temperature / storage temperature	°C	-40...+70 / -20...+55
IP rating		IP20
Relative humidity	%	85
Shock resistance	g	15
Vibration resistance	mm	0,35 10...55Hz
LED indicator		2 LED

The supervisory relay is designed for applications in automation and control systems to control the asymmetry, phase sequence and activating contactor's contacts in AC three-phase networks.

It is used to secure loads (eg. motors) from the voltage unbalance, incorrect phase sequence or damage to the executive contactor's contacts.

The relay has an adjustable off delay time range from 1s. to 6s. and an adjustable voltage asymmetry threshold from 30 to 70V. The relay is powered from L1 phase and does not protect from symmetric voltage drop. In case of detecting voltage asymmetry behind the executive contactor (at the V1, V2, V3 terminals) the relay will go off and disconnection and reconnection is required for restarting.

After the powering is given system will switch the contactor's circuit only in the absence of asymmetry and when the correct phase sequence is detected, regardless of the present, set time delay.

If you don't need to control contactor's contacts, the V1, V2 and V3 inputs can be left and remain unconnected.

Relay status is indicated by two LEDs.

Mounting

Mounted on DIN-rail TS 35 according to EN 60715

Mounting position: any

IP rating IP20

Tightening torque: max. 1 Nm

Terminal capacity: 1 x 0.5 to 2.5 mm² with/without multicore cable end 1 x 4 mm² without multicore cable end 2 x 0.5 to 1.5 mm² with/without multicore cable end 2 x 2.5 mm² flexible without multicore cable end

Danger!



Read and understand these instructions before installing, operating or maintaining the equipment.

Never carry out work on live parts! Danger of fatal injury! The product must not be used in case of obvious damage. To be installed by an authorized person.

Ordering information

MMR17-PDC-A230-108

Functions

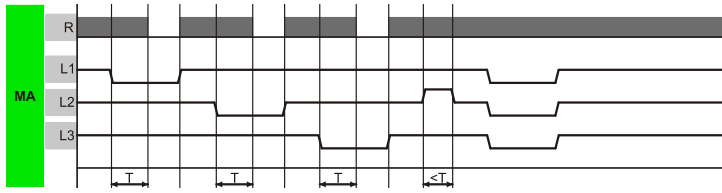

Functions - MA (asymmetry) – Asymmetry monitoring
As soon as the asymmetry exceeds the value at the U_{as} - regulator, the set interval of the tripping delay (DELAY) begins. After the interval has expired the output relay R switches into off-position (yellow LED not illuminated).

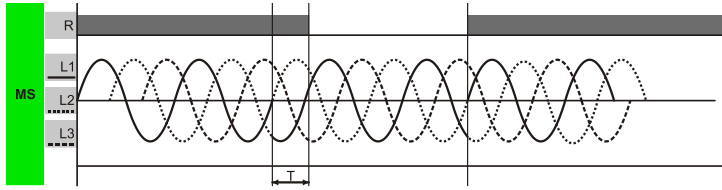

Function - MS (sequence) – Phase sequence monitoring
When all the phases are connected in the correct sequence and the measured asymmetry is less than the set value, the output relay switches into on-position (yellow LED illuminated). When the phase sequence changes, the output relay switches into off-position (yellow LED not illuminated).

2

Inspection contactor contacts

When it detects a voltage asymmetry for the contactor, the relay will be turned off permanently, and restart it requires disconnecting and reconnecting the power supply. This lock has been introduced to prevent the cyclic ON and OFF contactor.

Dimensions

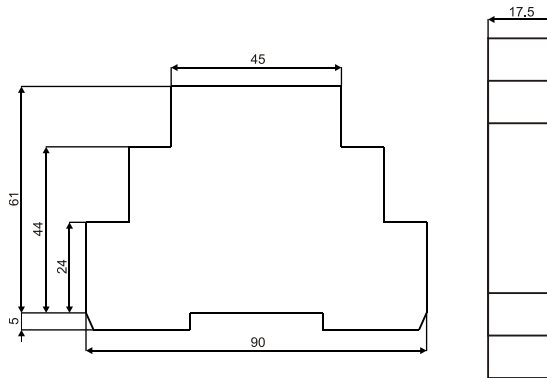

Front panel view

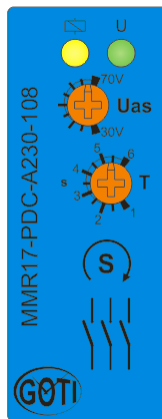

Connections diagrams

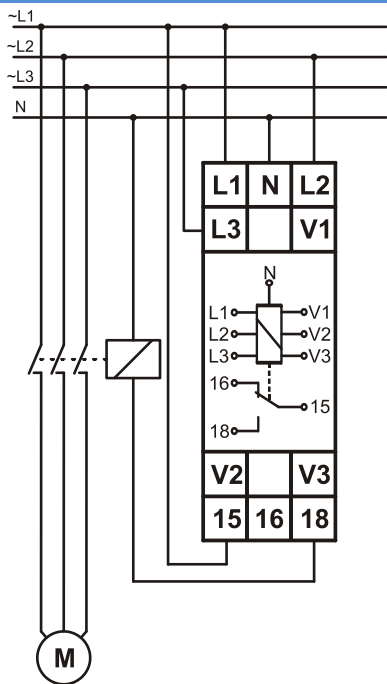

Out of control contactor contacts

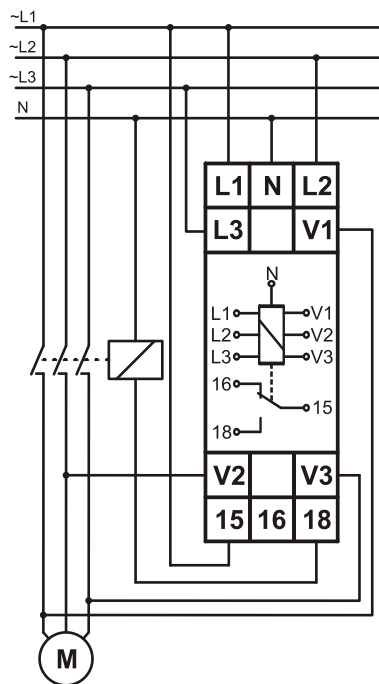

With the control contacts of the contactor

LED indicator

- Yellow LED indication of relay R output.
- Green LED indication of supply voltage.

